



# AMEREX MODEL 868 I-BEAM BRACKET ASSEMBLY INSTRUCTIONS

## INSTALLATION

This package contains all the necessary parts for the size bracket you have ordered.

To mount the 868 bracket across the flange of the beam:

Preassemble the bolts, washers, clips and rails to the beam clamps as shown in Figure 1 below. Hand tighten so that rails can slide freely through the clips. Note that the hole in the center of the clip is off center and that the clip should be rotated so that it does not extend beyond the edge of the beam clamp. With the remaining bolt, nut, and 2 washers, attach the appropriate fire extinguisher mounting bracket to the rails as shown by the dashed lines in Figure 1 and tighten with a 7/16" wrench. Slide one clamp assembly to each end of the rails. Align the bracket on the beam, fastening either of the clamps to the flange of the beam and tighten with a 5/16" wrench. Slide the remaining clamp onto the other lip of the flange and tighten with 5/16" wrench. Align the rails so that the fire extinguisher mounting bracket is centered on the beam and tighten the bolts with a 7/16" wrench. Each bolt must be securely tightened to ensure proper and safe installation of the bracket. Figures 2 and 3 below show proper installation of the bracket.

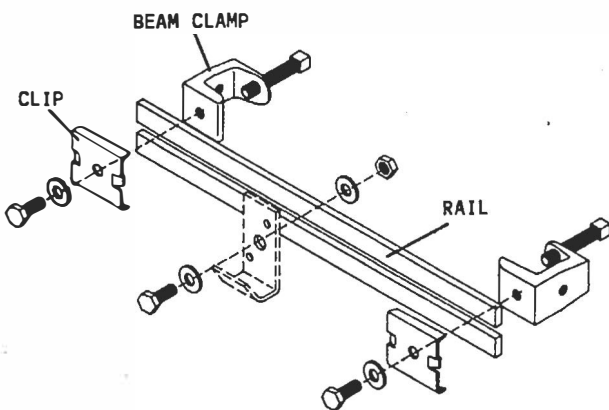

Figure 1.

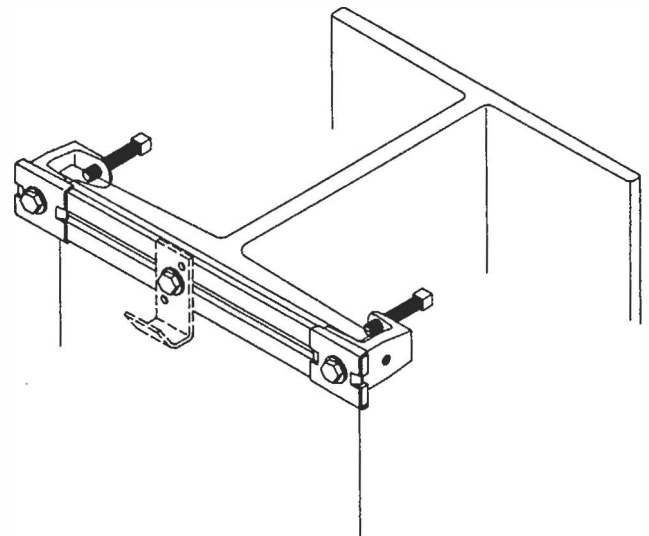

Figure 2.

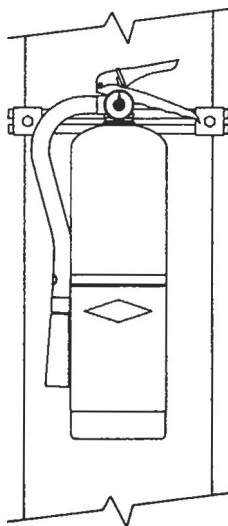

Figure 3.

See reverse for instructions on mounting across open face of beam.

To mount the 868 bracket across the open face of the beam:

If this bracket is used to hang an extinguisher across the open face of the beam it will be necessary to use two 868 brackets across the beam to prevent the extinguisher from tilting into the open face of the beam. Attach one as described below and one at the bottom of the extinguisher with no fire extinguisher mounting bracket attached. The lower bracket must be aligned so the bottom of the shell rests against it. See Figure 6 below. The Model 872 bracket has been designed specifically for extinguisher installation across the open face of the beam and may be the preferable bracket to use.

To install top 868 bracket:

Preassemble the bolts, washers, clips, and rails to the beam clamps as shown in Figure 4 below. Hand tighten so that rails can slide freely through the clips. Note that the hole in the center of the clip is off center and that the clip should be rotated so as not to extend beyond the edge of the beam clamp. Also note that the beam clamp bolts are to be aligned so as to fit on the inside of the beam. With the remaining bolt, nut, and 2 washers, attach the appropriate fire extinguisher mounting bracket to the rails as shown by the dashed lines in Figure 4 and tighten with a 7/16" wrench. Spread the clamp assemblies toward the ends of the rails to a width that matches that of the beam and attach the bracket to the beam. Tighten beam clamps with an 5/16" wrench. Align the fire extinguisher mounting bracket so that it is centered on the beam and between the clamps. Tighten the bolts through washers and clips with a 7/16" wrench. Each bolt must be securely tightened to ensure proper and safe installation of the bracket.

Note: On smaller beams where it is difficult to reach the beam clamp bolts with a wrench, it may be necessary to first attach the clamps to the beam and tighten, then apply the rails, clips, washers, and bolts.

To install bottom 868 bracket:

Follow above steps, omitting the fire extinguisher mounting bracket. Be sure to align bracket so that bottom of fire extinguisher cylinder rests against the rails of the bottom bracket. Figures 5 and 6 below show proper installation of the bracket.

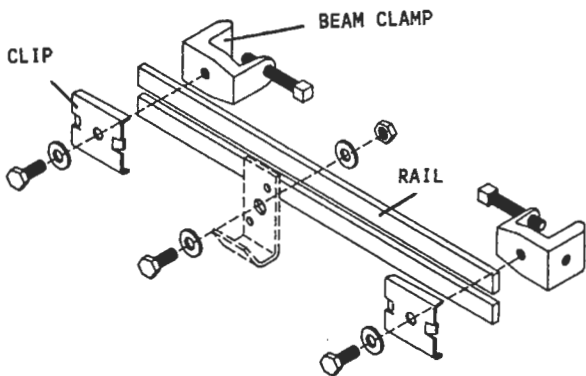

Figure 4.

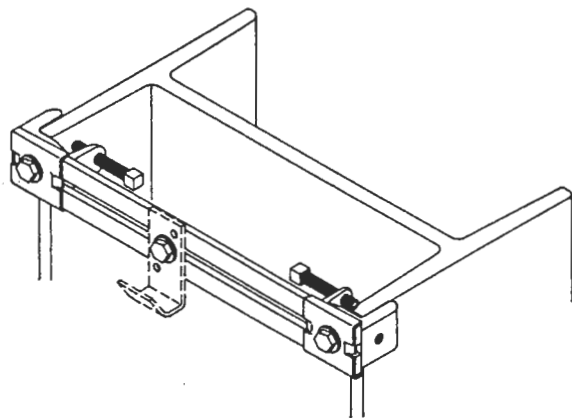

Figure 5.

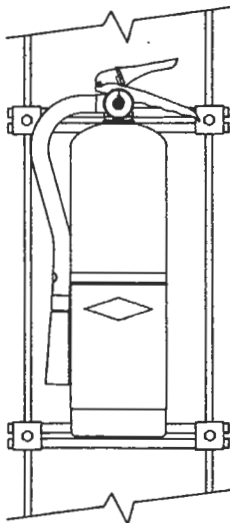

Figure 6.